

Laryngeal phonology in Plougrescant Breton: sandhi, mutation, and contrast

Pavel Iosad
Universitetet i Tromsø/CASTL
pavel.iosad@uit.no

Torontø–Tromsø Phonology Workshop
October 9–11 2009
University of Toronto

1. Laryngeal phonology in a Breton dialect
2. Final devoicing is loss of contrast, not loss of feature
3. Sandhi voicing is phonetic implementation (mostly)
4. Devoicing sandhi do not need [–voice]
5. Privative laryngeal features will do
6. Implications

Background

- ▶ Breton: a Celtic language, closely related to Cornish and Welsh
- ▶ Mostly described by Celtologists, dialectologists, and historical linguists
- ▶ Breton phonology remains seriously understudied (as opposed to syntax)
- ▶ Few proper phonetic studies, mostly aural transcriptions
- ▶ What can we do?

Previous work

Krämer (2000)

- ▶ Île de Groix Breton (Ternes, 1970)
- ▶ Argued to exhibit a ternary contrast between [+voice], [–voice], and [ovoice] segments
- ▶ Evidence for binary features
- ▶ Final devoicing is loss of features

Hall (2008)

- ▶ Same dialect, same source
- ▶ Privative features with feature geometry
- ▶ Feature disalignment
- ▶ Final devoicing is loss of features **and** loss of contrast

The present approach

- ▶ **Work in progress, (almost) nothing is final**
- ▶ Features are **privative** with feature geometry
- ▶ “Final devoicing” is loss of contrast
- ▶ Devoicing sandhi is
 - ▶ Either lexical phonology
 - ▶ Or failed mutation due to geminate inalterability
- ▶ Argument for substance-free phonology
- ▶ Tested on Plougrescant Breton (Jackson, 1960)

Consonant inventory

Manner	Place							
	Labial	Alveolar	Postalveolar	Palatal	Velar	Uvular	Laryngeal	
Stop	p b	t d		c ɟ	k g			
Fricative	f v	s z	ʃ			χ		h
Nasal	m	n		ɲ				
Lateral		l		ʎ				
Rhotic		r						
Glide	w			j				

- ▶ Length contrast for all consonants except voiced obstruents

Breton dialects

- ▶ Traditionally divided into four groups
 - ▶ Cornouaillais, Trégorrois, Léonais (KLT): relatively homogeneous, basis for standard language
 - ▶ Vannetais (south-east): very divergent, sometime even served by own literary tradition (Guillevic & Le Goff, 1902)
- ▶ Île de Groix is a **Vannetais** dialect
- ▶ Source rather messy (“phonemic” approach, not very systematic)
- ▶ Here: attempt to look at a less messy data point
- ▶ Plougrescant is a Trégorrois dialect; description by Jackson (1960) more systematic
- ▶ Further outlook: extend approach to Île de Groix if possible

Vowel inventory

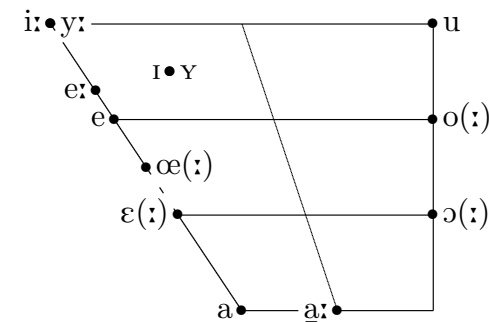

- ▶ Length is only licensed by (main) stress

Restrictions on laryngeal features

- ▶ Voiced and voiceless obstruents contrast word-initially; **short** allophones

(1)	a.	[ˈpɛsk]	‘fish’
	b.	[ˈbœ:rɛ]	‘morning’
	c.	[ˈlɔ:gɒt]	‘mice’

- ▶ Voiced and voiceless obstruents contrast immediately following unstressed vowels; **short** allophones:

(2)	a.	[bɔˈtɔ:]	‘shoes’
	b.	[ʃaˈdɛn:ət]	‘chained (participle)’
	c.	[kʏˈry:mɔ]	‘peals of thunder’

Restrictions on laryngeal features

- ▶ Word-finally following a stressed vowel, **voiced** obstruents are **not permitted**. Consonants are **short** following **long** stressed vowels and **long** following **short** stressed vowels.

(5)	a.	[ˈtɔ:k]	‘hat’
	b.	[ˈme:l]	‘honey’
(6)	a.	[ˈgrwɛk:]	‘woman, wife’
	b.	[mɛl:]	‘ball’

Restrictions on laryngeal features

- ▶ Following **long** stressed vowels, consonants can only be **short**; voiceless obstruents do not occur:

(3)	a.	[ˈɔ:ber]	‘to do; to make; to work’
	b.	[ˈli:zər]	‘letter’
	c.	[ˈme:lən]	‘yellow’

- ▶ Following **short** stressed vowels, consonants are **long**; voiced obstruents cannot be long, so they are excluded:

(4)	a.	[ˈtɑp:rʊt]	‘to take’
	b.	[ˈjɑχ:ɔχ]	‘more healthy’
	c.	[skʏˈdɛl:o]	‘basins’

Summary

- ▶ Leaving final devoicing aside for a moment, laryngeal features are mostly predictable:
- ▶ Laryngeal contrasts are allowed in the onset of the **first** syllable and of the **stressed** syllable
- ▶ Otherwise they are predictable:
 - ▶ **Voiced** following **unstressed** (always short) vowels
 - ▶ **Voiced** when single and following **long** stressed vowels
 - ▶ **Voiceless** (and long) when single and following **short** stressed vowels
- ▶ What is contrastive? What is marked?

Final devoicing

- ▶ At first blush final devoicing looks normal

(7) a. [byga'lɛjjo] 'children'
b. [bɣ'gɑ:lɪc] 'child'

- ▶ But what about vowel length?
- ▶ This is a good question

Final devoicing in monosyllables

- ▶ The really interesting part is when a stressed vowel precedes
- ▶ Stress is normally penultimate in KLT (but **not** in Vannetais!), so this is mostly monosyllables and a few words with final stress
- ▶ If it is vowel length that is distinctive, we expect V:C#

(8) a. ['tɔ:go] 'hats'
b. ['tɔ:k] 'hat'

- ▶ And cf. minimal pairs like

(9) a. ['kas:] 'send!' ([s] never voiced, French borrowing)
b. ['ka:s] 'cat' (cf. orthographic *kaz*)

Final devoicing in monosyllables

- ▶ This isn't really devoicing in view of what we know about quantity and voicing
- ▶ This is **incomplete** neutralization
- ▶ Confer real devoicing:

(10) a. [lɔ'gɔ:dən] 'mouse'
b. [lɔ'gɔ:t:a] 'to hunt mice'

- ▶ Side note: it isn't always about voicing per se:

(11) a. ['rɔ:his] 'people of ar Roc'h'
b. ['rɔ:χ] 'ar Roc'h (placename)'

- ▶ Not really surprising if you know (some) [h] is historically *χ, but must be accounted for

Final devoicing in monosyllables

- ▶ Does real final devoicing happen? Well, yes
- ▶ There is variation described by Jackson (1960) as “free”, and especially with coronals
- ▶ Context probably unknowable; the ambition here is at best to find which representations are involved

(12) [ty:t]~[tɣt:] 'people' (orthographic *tud*)

- ▶ More examples to come immediately below, as they involve sandhi to which we now turn
- ▶ What about lexically voiceless finals? These are relatively few, French borrowings of various antiquity, and behave as expected, cf. (9-a)

Sandhi

- ▶ The traditional view (Stephens, 1993; Favereau, 2001) is essentially that all consonants are voiced in sandhi before [+voice] segments

- (13) a. [ˈpwe:ləz ˈã.ɔ̃] ‘if you saw me’
b. [ˌmab ˈne:we] ‘new son’
c. [ˌpɔb ˈbi.ən] ‘little youth’

- ▶ And voiceless before voiceless consonants

- (14) a. [ˌmap ˈhi:r] ‘tall son’
b. [ən ˌdyt ˈkap:ap] ‘the able people’

Sandhi

- ▶ In the narrative texts given by Jackson (1960), the sandhi rules are often violated
- ▶ Especially with regard to sandhi voicing

- (16) a. [ˌmap ˈdy:] ‘black son’
b. [ˌmɛrɣ ˈvɑ:t] ‘good girl’
c. [ˈdwa:n tɔɛs ˈdi:wĩ] ‘the fear that you have of me’

- ▶ Jackson (1960) explains the texts were dictated at a slow pace
- ▶ However, some (in fact most) of the examples, such as (16-a) and (16-b), are transcribed with a secondary–main stress rhythm; these are possibly genuine connected phrases
- ▶ Thus failure of sandhi is not necessarily an artefact of dictation
- ▶ Note that vowels outside main-stressed syllables are shortened, so the preservation of length contrasts under devoicing does not work in the same way when stress is secondary

Sandhi

- ▶ Plus there is the devoicing sandhi that is the focus of Krämer (2000) and Hall (2008)
- ▶ For Île de Groix Ternes (1970) describes it as a lexical distribution: some words, and only these words, devoice initial obstruents following an obstruent
- ▶ For Plougrescant, Jackson (1960) is less concerned: “sometimes”

- (15) a. [ˈla:t tĩ] ‘said to me’, cf. [dĩ] ‘to me’
b. [ˈkankuf] ‘100 times’, cf. [ˈtɛrguf] ‘thrice’

Outline of analysis

- ▶ Outline feature analysis
- ▶ Argue that final devoicing without length permutations is a phonetic process
- ▶ Argue that sandhi voicing is the flip side of final devoicing
- ▶ Unify some devoicing sandhi with “failure of mutation”
- ▶ Tentatively propose that other devoicing sandhi are an artifact of univerbation

Feature analysis

- ▶ Before we even discuss final devoicing, we should solve the [voice]/[spread glottis] problem
- ▶ Phonetics rather poorly understood
- ▶ Voiceless stops are described as aspirated (at least initially) at Le Bourg Blanc (Falc'hun, 1951) and Saint-Pol-de-Léon (Sommerfelt, 1978), but these are both Léonais
- ▶ No mention of aspiration is made for Plougrescant by Jackson (1960, 1967)
- ▶ In all cases the voiced stops are described or assumed to be voiced
- ▶ One possible point: at Plougrescant fricatives underwent a context-free voicing (“new lenition”), cf. Southern English Fricative Voicing, which Honeybone (2005a) takes as evidence for [spread glottis]:∅
- ▶ But Honeybone (2005a) himself admits the analysis of fricatives should not be spread to stops uncritically

Final devoicing

- ▶ I propose that final devoicing is in fact loss of the laryngeal node, i. e. it is the exclusion of the very possibility of contrasting for laryngeal features
- ▶ Devoiced stops are a third phonological category: they behave differently from true voiceless stops in that they do not obey length-related restrictions
- ▶ True voiceless stops cannot follow long vowels; devoiced stops can
- ▶ In particular, what is the difference between final devoicing as in [ty:t] and final devoicing with gemination as in [tʏt:]?
- ▶ No tableaux in analysis (but hopefully it is pretty theory-independent)

Feature analysis

- ▶ In substance-free phonology with emergent privative features, this point is rather moot
- ▶ We are interested in the patterning, whether the “voiceless” obstruents are labelled [spread glottis] or [voiceless] (cf. Blaho, 2008) is irrelevant
- ▶ Or voiced stops are [voice] or [stiff], of course
- ▶ I propose that in Plougrescant Breton “voiceless stops” are [voiceless] and “voiced stops” do not bear a laryngeal feature, but do have a laryngeal node
- ▶ I return below to why nodes are better than features
- ▶ Main reason is restricted distribution: only initial and stressed syllables, both reasonable contexts for positional faithfulness (Beckman, 1999; Smith, 2002)
- ▶ We **need** to make reference to this feature to derive the restrictions (but not to describe final devoicing as I argue below)
- ▶ In that sense it is “marked” (Trubetzkoyan markedness)

Assumptions of analysis

- ▶ Vowel length distinctive in main-stressed syllables: faithfulness \gg markedness in this context
- ▶ *[voiceless] above MAX[vcl]
- ▶ Except for positional faithfulness: MAX[vcl]/Initial and MAX[vcl]/ó above *[vcl]
- ▶ Bimoraic template for main-stress syllable (MAIN-TO-WEIGHT): McGarrity (2003); Bye & de Lacy (2008)
- ▶ Final devoicing driven by a constraint *Lar/[_]_{wd} militating against any segments with a laryngeal node at the end of a (morphological?) Word

Medial obstruents: /Vt/

- ▶ Obstruents are long and voiceless following short stressed vowels

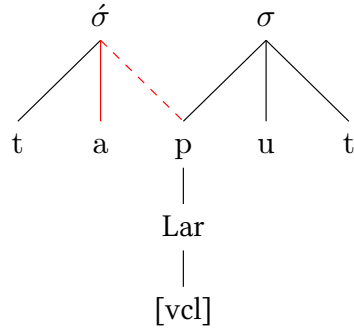

- ▶ The voiceless obstruent piggybacks on MAIN-TO-WEIGHT to be parsed into the stressed syllable and thus keep [vcl]
- ▶ This is assuming (as I do) that faithfulness to vowel length is undominated

Medial obstruents: /Vd/

- ▶ The obstruent loses its laryngeal specification in order to become moraic for the benefit of MAIN-TO-WEIGHT
- ▶ Laryngeally unspecified obstruent geminates are realized as voiceless for obvious phonetic reasons
- ▶ Maybe these are excluded by Lexicon Optimization since the learner never really has to posit /b̥:/?

Medial obstruents: /Vd/

- ▶ Assuming richness of the base, what happens with voiced obstruents after short vowels?

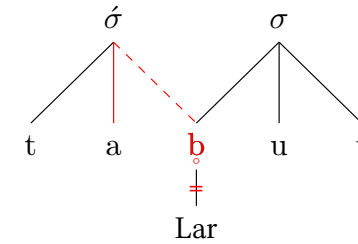

- ▶ Assume a constraint *Lar/μ: geminates without laryngeal specifications exist in the language (geminate sonorants)
- ▶ This is of course outranked by positional faithfulness to [vcl] to derive the previous case

Medial obstruents: /V:t/

- ▶ This is a simple case

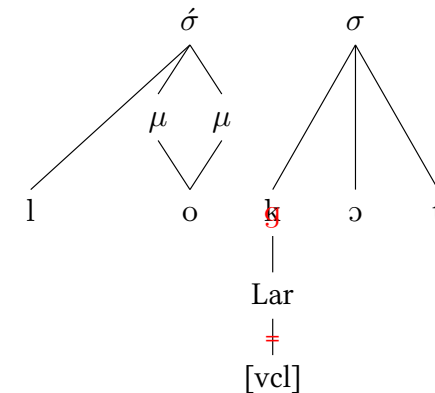

- ▶ No superheavy syllables, so [vcl] cannot be saved

Final devoicing: voiced stops

- ▶ No Lar node word-finally
- ▶ Final consonant is extrametrical (so maybe no Lar node not licensed by prosodic structure?)
 - ▶ Stress: ultimate if V: in final syllable, else penultimate. Moraic trochee, but then final VC must be L

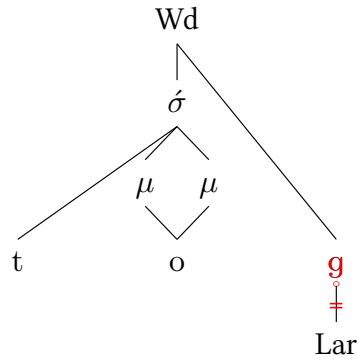

Final devoicing: voiced stops

- ▶ Laryngeally unspecified obstruents in pausa are realized as voiceless, phonetic reasons are well-known
- ▶ What if our [vcl] is really [spread glottis] in this dialect?
- ▶ It is apparently unproblematic to have aspiration as the phonetically natural realization of phonological underspecification (Vaux & Samuels, 2005)
- ▶ What about cases such as [ty:t]~[tyt:]?
- ▶ I propose this is real final devoicing, i. e. the imposition of the [vcl] feature at word (phrase?) edges (Iverson & Salmons, 2007)
- ▶ First let's look at underlying voiceless obstruents

Final voiceless stops

- ▶ The [vcl] obstruent becomes moraic to satisfy MAIN-TO-WEIGHT, so the restrictions on vocalic quantity hold

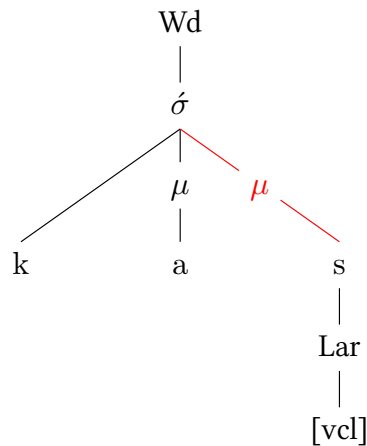

True final devoicing

- ▶ In this scenario, forms such as [tyt:] for /tyd/ imply that the constraint driving final devoicing is ranked over faithfulness for vowel length.

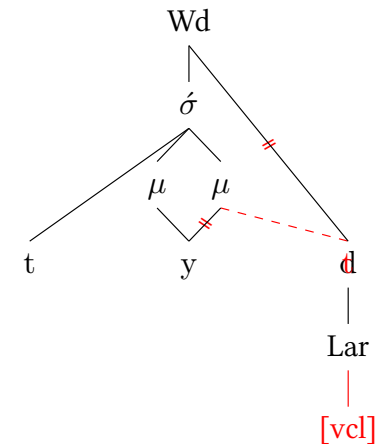

Final devoicing: summary

- ▶ I have argued that what looks like normal final devoicing is in fact the deletion of a Lar node, or **absence of contrast**
- ▶ Further evidence: final /v/ does not always neutralize with /f/ phonetically: Jackson (1960) writes [v̥]
- ▶ We know [v] is aerodynamically complicated (Padgett, to appear)
- ▶ So this would be consistent with a phonologically underspecified /v̥/?
- ▶ Final devoicing as final fortition (Iverson & Salmons, 2007) is distinct from this process and also attested
- ▶ Grazing other dialects: final devoicing is optional at Saint-Pol-de-Léon (Sommerfelt, 1978) (?)

Voicing assimilation sandhi

- ▶ Before obstruents, we are faced with two options
- ▶ Same as above
 - ▶ Explains possible devoicing even before voiced obstruents
 - ▶ Possibly predicts that under certain phonetic circumstances final consonants may be voiced before voiceless consonants?
- ▶ Spread of Lar, with [vcl] if need be
 - ▶ Variation must have a phonological explanation (stochastic ranking?)
 - ▶ Devoicing sandhi crucial piece of evidence in favour

Voicing sandhi

- ▶ In this system, voicing sandhi arise from two sources
- ▶ Before sonorants: laryngeally unmarked stops are voiced in the phonetics
- ▶ Sonorants do not contrast for laryngeal features, so they do not have a [Lar] to spread
- ▶ Explains variability (pause-sensitivity?)
- ▶ No need to have (contrastive) laryngeal features for sonorants (Krämer, 2000; Blaho, 2008; Hall, 2008)
- ▶ [ˌm̩ab 'ne:we] = /m̩ab̥ ne:we/

Devoicing sandhi

- ▶ Some examples of devoicing sandhi
 - (17) a. [ˈla:t t̩ĩ] 'said to me'
 - b. [me 'gaf t̩ĩ] 'I find, I consider' (lit. 'I get to me')
 - c. [ˌdɔ 'wen:ək 't̩it] 'your two sous' (lit. 'two sous to you')
- ▶ Prepositions are overrepresented
- ▶ Actually, this is also true of Île de Groix!
- (18) [tra nə'vaŋk t̩emp] 'we don't miss anything' (lit. 'nothing is missing to us')
- ▶ What's with the prepositions?

Detour 1: mutation

- ▶ Breton is (widely?) known for its initial consonant mutation
- ▶ Here we are only interested in lenition

Underlying	p	t	k	b	d	g	m
Mutated	b	d	g	v	z	h	v

- ▶ The interesting bit is the voicing of voiceless stops

Detour 2: prepositions

- ▶ Historically, prepositions in Brythonic have tended to undergo the effects of soft mutation/lenition in a context-free way
- ▶ Old Welsh and Old Breton *gurth* ‘through’, Modern Welsh *wrth*, Modern Breton *ouzh*
- ▶ Old Welsh *di* ‘to’, Modern Welsh *i* (via *[ði])
- ▶ Modern Welsh variation: *trwy* ~ *drwy* ‘through’

Detour 2: prepositions

- ▶ Why is this important?
- ▶ At least in Welsh, there is evidence that the new initial consonant is not fully lexicalized
- ▶ In particular, **gan* ‘with’ is historically **kant*
- ▶ The conjunction *a* ‘and’ causes a mutation whereby voiceless stops are spirantized to [f θ χ] but voiced ones are unaffected
- ▶ We expect **a gan* for ‘and with’, but it is actually *a chan* (Morgan, 1952; Ball & Müller, 1992)
- ▶ The same is true of *dros* and *drwy* though there the variants with the voiceless stop survive in the modern language
- ▶ So maybe *gan* is really [L]*can* underlyingly
- ▶ Where [L] is the autosegment (Wolf, 2007)

Back to Breton: devoicing sandhi

- ▶ I propose that (some) Breton devoicing sandhi reflect the same incomplete lexicalization of the voiced stops
- ▶ Consider *lavare*[t t]iñ

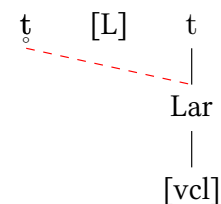

- ▶ Normally, [L] docks to the following /t/, e. g. due to MAXFLT (Wolf, 2007)
- ▶ But not when the Lar node spreads to a preceding root node

Devoicing sandhi

- ▶ This can be for any number of reasons
 - ▶ Some version of geminate inalterability
 - ▶ Structure sharing inhibits weakening processes (Honeybone, 2005b)
 - ▶ Under certain assumptions, the structure shown is not convex (Scobbie, 1997)

Devoicing sandhi

- ▶ This is the same phenomenon: an autosegment normally leading to voicing is inhibited by spreading of the Lar node
- ▶ Following sonorants the Lar node can't spread since sonorants with a Lar node are never well-formed
- ▶ But this time we have much better evidence for the autosegment being there
- ▶ The same data are described by Ternes (1970) in an extremely convoluted way...
- ▶ The generalization: if an obstruent is voiced by an autosegment, it can resist voicing by spreading Lar to a preceding obstruent

Devoicing sandhi

- ▶ Further evidence for this approach comes from so-called “failure of mutation” (Jackson, 1967, §481)
- ▶ Lenition of voiceless stops is said to “fail” when an adjective (given the necessary morphosyntactic conditions) follows an obstruent-final noun
- ▶ But with sonorant-final nouns or voiced stops mutation happens
- ▶ Cf. *kaer* ‘beautiful’
 - (19) a. un dimezell **gaer**
a maiden beautiful
 - b. ur vaouez **kaer**
a woman beautiful
- ▶ Morphosyntax actually irrelevant, since other triggers of this mutation are sonorant-final

What, autosegments?

- ▶ In previous work I have doubted that the autosegmental approach is suited to Brythonic Celtic mutations (cf. also Green, 2006)
- ▶ I think these data are actually pretty solid evidence for autosegments or at least for a phonological analysis
- ▶ Breton is less problematic than Welsh morphosyntactically
- ▶ Breton mutation seems to be genuinely sensitive to prosody (Pyatt, 2003)
- ▶ There is still the problem of doing mutation phonologically: Wolf (2007) covers only a small subset
- ▶ In particular, the autosegment should cause deletion of [vcl] in the current approach
- ▶ Problem! But see Bye & Svenonius (2009) for an approach...

More devoicing sandhi

- ▶ Other types of devoicing sandhi do not seem to fall under this rubric

(20) a. [san kɔ'ne:ri] 'Saint Gonery'
b. ['kankuɸ] 'thrice', cf. [tɛrguɸ] 'thrice'

- ▶ I propose that here devoicing is due to univerbation, i. e. the relevant words are now compounds
- ▶ Word-internally voiceless obstruent clusters are (nearly) universal (also noted by Hall, 2008 for Île de Groix)

More devoicing sandhi

- ▶ Jackson (1967, §487): “provection in common phrases”
- ▶ Are these actually phrases or words?
 - ▶ Saint Gonéry is the patron saint of the local chapel



- ▶ ‘Thrice’ might well be a single word, cf. Welsh *dwywaith* ‘twice’, and in fact *[guɸ] is the reduced form, cf. stressed *gwej* ‘time, occasion’
- ▶ Etc.

Photo credit: Steffen Heilfort. Source.

Summary and outlook: sandhi

- ▶ Voicing sandhi are mostly due to phonetic implementation of laryngeally unspecified obstruents in a phrasal context
- ▶ Some devoicing sandhi are due to inhibition of autosegmentally induced voicing
- ▶ Others might possibly be not phrasal sandhi at all
- ▶ Both of these phenomena seem to be cross-dialectal, so the account possibly extends to Île de Groix:
 - ▶ Prepositions
 - ▶ More examples: the “devoicing” word [bə'nak] ‘any’ is Middle Breton *pennac* (Lewis & Piette, 1962, §45)
 - ▶ The “provection in common phrases” (univerbation) is described as pan-Breton. Examples of devoicing sandhi in Île de Groix include ‘grey peas’ and ‘little finger’—intuitively good candidates for univerbation

Loss of feature or loss of contrast

- ▶ Here I have argued that Breton presents examples two types of final devoicing
 - ▶ Final devoicing as loss of contrast: cf. the arguments of Harris (2009) for FD as weakening
 - ▶ Final devoicing as edge alignment: final fortition (Iverson & Salmons, 2007)
- ▶ Take-home message here: there is no process of “final devoicing”, “final weakening” or “final fortition” that we can speak of in universal terms
- ▶ Argument for substance-free phonology

Final devoicing as phonetics

- ▶ Growing body of work on final devoicing (and generally laryngeal assimilation) as a “low-level phonetic process”
- ▶ The *Paradestück* here is of course Dutch (Ernestus & Baayen, 2006, 2007; Jansen, 2007)
- ▶ Possibly others (e. g. the disputed claim for Polish)
- ▶ Breton seems to show quite good evidence for incomplete neutralization
- ▶ Laryngeally unspecified segments interpreted by the phonetics as devoiced or aspirated rather than [–voice] or [spread glottis] specified
- ▶ Needs careful cross-linguistic study

Ternary contrasts

- ▶ One answer: who says we never need bigger feature geometry trees? It is correct that arboreal representations can have many levels, but maybe this is empirically better?
- ▶ Related answer: binary features are no more God-given/less stipulative: [ovoice], [1voice] and [2voice] are also a notational variant, but these are as overgenerating as trees
- ▶ Reason: three independent values of [F] cannot capture implication relations in the same way that feature geometry can
- ▶ Here I argue that the feature geometry/underspecification approach is empirically more adequate than one based on [±voice] spreading

Ternary contrasts

- ▶ Krämer (2000) argues that the presence of both voicing and devoicing necessitates binary features, i. e. a ternary contrast
- ▶ Related issue: Uffmann (2009) asks how to distinguish between categorically voiceless and laryngeally unspecified stops in a privative system
- ▶ The answer is of course feature geometry
- ▶ Objection of Uffmann (2009): but this is an overgenerating notational variant of binary features

Tiers or features?

- ▶ Here I use class nodes (as in e. g. Avery, 1996)
- ▶ Blaho (2008): no need for nodes if features can do the job, e. g. substitute Lar with [obst] since only obstruents are laryngeally specified
- ▶ Gives strange results for Breton, since final devoicing is driven by *[obst]: works formally but how insightful is it? Are the devoiced obstruents sonorants? (Well, why not)
- ▶ Here: nodes are necessary

- ▶ If features can only attach to nodes, the presence of a node (even with no features) is the formal correspondent of contrastive specification
- ▶ Sort of answers the concern of Uffmann (2009) on the difference between two types of feature absence
- ▶ Without nodes, how do we define tiers and all the autosegmental phenomena that come with them?
- ▶ Null hypothesis: all and only features dependent on a specific node are on the same autosegmental tier
- ▶ Field of empirical inquiry

Avery, Peter J. 1996. *The representation of voicing contrasts*. Ph.D. thesis, University of Toronto.

Ball, Martin J. & Nicole Müller. 1992. *Mutation in Welsh*. London—New York: Routledge.

Beckman, Jill N. 1999. *Positional faithfulness*. Ph.D. thesis, University of Massachusetts, Amherst.

Blaho, Sylvia. 2008. *The syntax of phonology: a radically substance-free approach*. Ph.D. thesis, University of Tromsø.

Bye, Patrik & Paul de Lacy. 2008. Metrical influences on fortition and lenition. In Joaquim Brandaõ de Carvalho, Tobias Scheer & Philippe Ségéral (eds.), *Lenition and fortition*, vol. 99, Studies in generative grammar, 173–2006. Berlin: Mouton de Gruyter.

Bye, Patrik & Peter Svenonius. 2009. Extended exponence and non-concatenative morphology. MS., University of Tromsø.

Ernestus, Mirjam & R. Harald Baayen. 2006. The functionality of incomplete neutralization in Dutch: the case of past-tense formation. In Louis M. Goldstein, D. H. Whalen & Catherine T. Best (eds.), *Laboratory phonology 8*, 27–49. Berlin: Mouton de Gruyter.

- ▶ New interpretation of Breton data
- ▶ Possible cross-dialectal extension
- ▶ Privative features can do the job
- ▶ Feature/node geometry is preferable to binary features and (possibly) to node-less geometry.

Trugarez!

Ernestus, Mirjam & R. Harald Baayen. 2007. Intraparadigmatic effects on the perception of voice. In van de Weijer & van der Torre (2007), 153–173.

Falc'hun, François. 1951. *Le système consonantique du breton*. Rennes: Pilhon.

Favereau, Francis. 2001. *Grammaire du breton contemporain*. Morlaix: Skol Vreizh.

Green, Anthony Dubach. 2006. The independence of phonology and morphology: The Celtic mutations. *Lingua* 116(11). 1946–1985.

Guillevic, Augustin & Pierre Le Goff. 1902. *Grammaire bretonne du dialecte de Vannes*. Vannes: Lafolye Frères.

Hall, Daniel Currie. 2008. On the voicing system of île de Groix Breton. Presentation at the Workshop on phonological voicing variation, Leiden.

Harris, John. 2009. Why final obstruent devoicing is weakening. In Kuniya Nasukawa & Phillip Backley (eds.), *Strength relations in phonology*, vol. 103, Studies in generative grammar, 9–46. Berlin: Mouton de Gruyter.

- Honeybone, Patrick. 2005a. Diachronic evidence in segmental phonology: the case of obstruent laryngeal specification. In Marc van Oostendorp & Jeroen van de Weijer (eds.), *The internal organization of phonological segments*, vol. 77, Studies in Generative Grammar, 319–354. Mouton de Gruyter.
- Honeybone, Patrick. 2005b. Sharing makes us stronger: process inhibition and segmental structure. In Philip Carr, Jacques Durand & Colin J. Ewen (eds.), *Headhood, elements, specification, and contrastivity: Phonological papers in honour of John Anderson*, 167–192. Amsterdam: John Benjamins.
- Iverson, Gregory K. & Joseph C. Salmons. 2007. Domains and directionality in the evolution of German final fortition. *Phonology* 24(1). 121–145. doi:10.1017/S0952675707001133.
- Jackson, Kenneth Hurlstone. 1960. The phonology of the Breton dialect of Plougrescant. *Études celtiques* 9. 327–404.
- Jackson, Kenneth Hurlstone. 1967. *A historical phonology of Breton*. Dublin: DIAS.
- Scobbie, James M. 1997. *Autosegmental representation in a declarative constraint-based framework*. New York: Garland.
- Smith, Jennifer L. 2002. *Phonological augmentation in prominent positions*. Ph.D. thesis, University of Massachusetts, Amherst.
- Sommerfelt, Alf. 1978. *Le breton parlé à Saint-Pol-de-Léon*. Oslo, Bergen, Tromsø: Universitetsforlaget. Édité par Frañsez Falc’hun et Magne Oftedal.
- Stephens, Janig. 1993. Breton. In Martin J. Ball & James Fife (eds.), *The Celtic languages*, 349–409. London and New York: Routledge.
- Ternes, Elmar. 1970. *Grammaire structurale du breton de l’île de Groix (dialecte occidental)*. Heidelberg: Carl Winter Universitätsverlag.
- Uffmann, Christian. 2009. To (bi) or not to (bi). Presentation at the Privative Project workshop, Old World Conference in Phonology 6, Edinburgh.
- Vaux, Bert & Bridget Samuels. 2005. Laryngeal markedness and aspiration. *Phonology* 22(3). 395–436. doi:10.1017/S0952675705000667.
- Jansen, Wouter. 2007. Dutch regressive voicing assimilation as a “low level phonetic process”: acoustic evidence. In van de Weijer & van der Torre (2007), 123–151.
- Krämer, Martin. 2000. Voicing alternations and underlying representations: the case of Breton. *Lingua* 110. 639–663.
- Lewis, Henry & J. R. F. Piette. 1962. *Llawlyfr Llydaweg Canol*. Caerdydd: Gwasg Prifysgol Cymru.
- McGarrity, Laura W. 2003. *Constraints on patterns of primary and secondary stress*. Ph.D. thesis, Indiana University.
- Morgan, Thomas John. 1952. *Y treigladau a’u cystrawen*. Caerdydd: Gwasg Prifysgol Cymru.
- Padgett, Jaye. to appear. Russian voicing assimilation, final devoicing and the problem of [v]. *Natural Language and Linguistic Theory*.
- Pyatt, Elizabeth J. 2003. Relativized mutation domains in the Celtic languages. In Elsi Kaiser & Sudha Arunachalam (eds.), *Proceedings from the Penn Linguistics Colloquium 26*. Philadelphia: University of Pennsylvania.
- van de Weijer, Jeroen & Jan Erik van der Torre (eds.). 2007. *Voicing in Dutch*, vol. 286, Current issues in linguistic theory. Amsterdam: John Benjamins.
- Wolf, Matthew. 2007. For an autosegmental theory of mutation. In Michael O’Keefe, Ehren Reilly & Adam Werle (eds.), *University of Massachusetts Occasional Papers in Linguistics 32: Papers in Optimality Theory III*, 315–404. Amherst: GLSA.